



AGENDA FOR STUDY SESSION
ASHLAND PARKS & RECREATION COMMISSION
August 2, 2023
Electronic Meeting – 6 P.M.

Public Participation Instructions

This meeting will be held electronically via Zoom Webinar. Registration is required to view the meeting. A link to the meeting will be sent to you once registration has been completed: https://zoom.us/webinar/register/WN_QaAPxJriTounSKVo2QTVSw

Written testimony will be accepted via email sent to sean.sullivan@ashland.or.us. Please include “**Public Testimony**” in the subject line. Written testimony submitted before 12:00 pm the Tuesday before the meeting will be made available to the Parks Commissioners before the meeting. All testimony will be included in the meetings minutes.

Oral Testimony will be taken during the electronic public meeting. If you wish to provide oral testimony, send an email to sean.sullivan@ashland.or.us, preferably before 12:00 pm the Tuesday before the meeting. Late requests will be honored if possible. Please provide the following information: 1) make the subject line of the email “**Speaker Request**”, 2) include your name, 3) the agenda item on which you wish to speak on, 4) specify if you will be participating by computer or telephone, and 5) the name you will use if participating by computer (Zoom Name) or the telephone number you will use if participating by telephone. Staff will provide information necessary to join the meeting upon request.

- I. CALL TO ORDER
- II. PUBLIC FORUM
- III. VACANT APCR COMMISSION SEAT APPLICATION PROCESS
- IV. BUTLER PEROZZI FOUNTAIN PLAQUE REQUEST
- V. CONVERSATION CLUSTER SEATING PROJECT
- VI. DISCUSSION REGARDING RESTRICTIONS ON ALCOHOL IN PARKS
- VII. LOOKAHEAD REVIEW
- VIII. ITEMS FROM COMMISSIONERS/STAFF
- IX. ADJOURNMENT

In compliance with the Americans with Disabilities Act, if you need special assistance to participate in this meeting, please contact the City Administrator’s office at (541) 488-6002 (TTY phone number (800) 735-2900). Notification 72 hours prior to the meeting will enable the City to make reasonable arrangements to ensure accessibility to the meeting (28 CFR 35.102-35.104 ADA Title I). Parks Commission meetings are broadcast live on Channel 9, or on CHARTER CABLE CHANNEL 180. Visit the City of Ashland’s website at www.ashland.or.us.

ASHLAND PARKS & RECREATION COMMISSION

340 S PIONEER STREET • ASHLAND, OREGON 97520

COMMISSIONERS:

Rick Landt
Leslie Eldridge
Jim Lewis
Jim Bachman
Justin Adams



Michael A. Black, AICP
Director

541.488.5340
AshlandParksandRec.org
parksinfo@ashland.or.us

STAFF MEMORANDUM

TO: Ashland Parks and Recreation Commissioners

FROM: Rachel Dials, Deputy Director

DATE: July 27, 2023

SUBJECT: Butler Perozzi Fountain Restoration Plaque (Informational)

The Ashland Parks Foundation will present a proposal to place a plaque at the Butler Perozzi Fountain location that would commemorate the restoration project the foundation is currently raising funds for. This item is informational only and would be placed on a business meeting agenda for action at the direction of the Commissioners.

ASHLAND PARKS & RECREATION COMMISSION

340 S PIONEER STREET • ASHLAND, OREGON 97520

COMMISSIONERS:

Rick Landt
Leslie Eldridge
Jim Lewis
Jim Bachman
Justin Adams



Michael A. Black, AICP
Director

541.488.5340
AshlandParksandRec.org
parksinfo@ashland.or.us

STAFF MEMORANDUM

TO: Ashland Parks and Recreation Commissioners

FROM: Isleen Glatt, Senior Services Superintendent

DATE: 7/25/23

SUBJECT: Conversation Clusters Seating Project Grant

Situation

In April 2023, staff presented details of a grant application to the AARP Community Challenge requesting \$12,550 to create “conversation clusters” seating in parks. AARP did not fund this application. Knowing that a 2nd year of funding from AARP was unlikely, former Director Black had also set aside \$6000 in funding from APRC’s CIP budget to fund conversation clusters. The proposal below is modified to reduce costs.

The demonstration project would create three new public seating options designed to encourage social connection in public spaces, then solicit community feedback on the designs.

Background

The Senior Services Division represents Ashland Parks and Recreation on the Livable Ashland Alliance, the now independent group which grew out of the AARP Age-Friendly Communities application that was endorsed by the Commission. Members of the Alliance have requested conversation cluster seating in APRC parks as an all-age-friendly addition to livability in our community.

Conversational seating has been particularly requested by older adults seeking a safe, outdoor place to meet with friends and colleagues. While all community members are welcome to gather in public parks, park benches do not traditionally face each other. Seating that allows park users to face each other for conversation is especially important for older adults, many of whom are not comfortable sitting on the ground.

The original project would install three unique seating configurations tentatively planned for three park locations as recommended by Director Black. On June 26, Commission Chair Rick Landt viewed the three

potential sites with staff and Livable Ashland Alliance Co-Chair Anne Bellegia. Chair Landt recommended some modifications to the plan.

Assessment

The proposed project is a relatively low-cost way to meet a community request while testing the efficacy of different models. This modified proposal recommends wooden benches made in house rather than the expensive, but more lasting metal benches. Based on the proposed locations, wooden benches are consistent with current standards to use metal benches only in more formal locations.

- 1) **A set of 20 stacking chairs** in Lithia Park bottom green, at front west corner. Chairs would be stacked on the mulch, available for community members to move and position as desired. Signage will ask people to return chairs when done, but staff will have to restack when mowing.



- 2) **A semi-circle of three 5' benches** in Garfield Park near corner of East Main and California Streets. This project will add two 5' benches to an existing 5' wooden bench, with wood replaced on the existing bench. One option is to make the two new benches movable to allow mowing, as with some nearby picnic tables. However, parks staff note that lighter movable items at Garfield Park tend to disappear, and they report that string trimming is no more work than stopping the mower to move benches away and back.

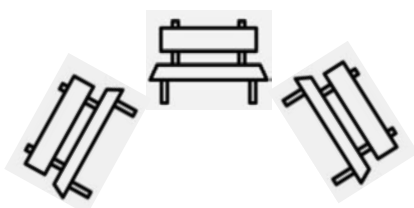

- 3) **A circle of 4 fixed wooden 6' benches in Glenwood Park**, near the corner of Ashland St and Glenwood Drive. Project will reclaim space from an area where irrigation has been a long-term challenge, currently covered in St. John's wart and underperforming grass. For this closed circle, staff recommend a decomposed granite pad under the benches.

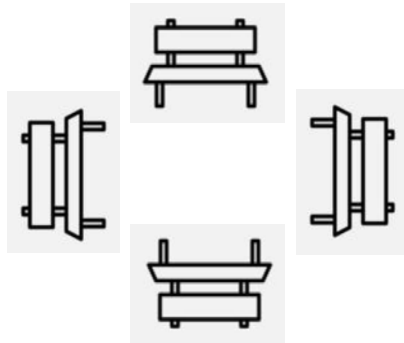

Option 1 is the biggest experiment, to see if the public can responsibly use and return the stacking chairs. Because cost per chair is low, the risk is low in this experiment. We may test leaving the chairs stacked in place overnight versus the staff time required to lock or store them at night. If this model causes problems, the chairs could be relocated or the experiment terminated.

For Options 2 and 3, the benches would be spaced to allow someone with a walker or wheelchair to join. We expect to leave this seating in place for the life of the benches, unless there are unforeseen circumstances.

Recommendation

We are requesting Commissioner feedback on the proposed project and proposed use of CIP funds. After discussion, this item may return to the Commission on August 9 for a decision.

ASHLAND PARKS & RECREATION COMMISSION

340 S PIONEER STREET • ASHLAND, OREGON 97520

COMMISSIONERS:

Rick Landt
Jim Lewis
Jim Bachman
Justin Adams



541.488.5340
AshlandParksandRec.org
parksinfo@ashland.or.us

STAFF MEMORANDUM

TO: Ashland Parks and Recreation Commissioners
FROM: Rachel Dials, Deputy Director
DATE: July 27, 2023
SUBJECT: Alcohol in Parks Discussion

SITUATION

1. At the regular meeting on January 27, 2020 the Commissioners approved the recommendation for a municipal code change to *10.68.090 Intoxicating Liquor Prohibited* as presented by staff, including amendments presented in the staff report. The motion included that it would not go to the City Council until the Commissioners have reviewed and approved the rules and guidelines. Then the Covid-19 pandemic occurred, and our work and progress were sidelined. As part of the current Biennium goals, the Commission seeks to “support opportunities for community building through programs and events in our parks, open spaces and trail networks that celebrate art, music, sports and nature.” A proposed change to the alcohol policy would support that goal.

BACKGROUND

The Commission approved the amendments below to *10.68.090 Intoxicating Liquor Prohibited*:

It is unlawful for any person to take any intoxicating liquor or beverage into any portion of the public parks of the City, except ~~that~~ as authorized by the Ashland Parks and Recreation Commission, consistent with established parks rules and regulations.

A. ~~Intoxicating liquor or beverages may be transported through the Lithia Park extension area which is located between North Main Street and Winburn Way and between Ashland Creek to the west and the Plaza to the east.~~

B. ~~This section and the prohibitions on the possession and use of intoxicating liquor shall not apply to that portion of the park that is leased to the Oregon Shakespeare Festival Association.~~

~~C. This section and the prohibitions on the provision and use of intoxicating liquor shall not apply to the park property commonly known as Calle Guanajuato only when such is served with prepared meals and with the express approval of the Ashland Park and Recreation Commission and the Oregon Liquor Control Commission.~~

~~D. This section and the prohibitions on the provision and use of intoxicating liquor shall not apply to the park property commonly known as Oak Knoll Golf Course only when such is served as part of the City Golf Course operation or approved concession with the approval of the Ashland Park and Recreation Commission and the Oregon Liquor Control Commission.~~

E. Any person who violates any provision of this Chapter is subject to Section [1.08.020](#) of the Ashland Municipal Code. Any violation of this section is a Class II violation. (Ord. 3137, amended, 2017; Ord. 3026, amended, 08/03/2010)

At the meeting in January of 2020 the Commission gave direction that rules and guidelines be established and approved prior to the ordinance change going to the City Council. Staff is restarting the discussion on rules and guidelines and would like input from the Commission this evening.

A draft of rules and guidelines will be presented at the study session on August 2, 2023.

Electronic Attachment

[Meeting minutes from January 27, 2020](#)

ASHLAND PARKS & RECREATION COMMISSION

340 S PIONEER STREET • ASHLAND, OREGON 97520

COMMISSIONERS:

Rick Landt
Leslie Eldridge
Jim Lewis
Jim Bachman
Justin Adams



Michael A. Black, AICP
Director

541.488.5340
AshlandParksandRec.org
parksinfo@ashland.or.us

STAFF MEMORANDUM

TO: Ashland Parks and Recreation Commissioners

FROM: Rachel Dials, Deputy Director

DATE: July 27, 2023

SUBJECT: Lookahead Review and Direction (Direction to Staff)

The latest lookahead is being provided for Commissioners to review and provide direction to staff.

Attachment
July 26, 2023 Lookahead

Ashland Parks and Recreation Commission Lookahead

Updated on 7/26/2023

		Information	Action	Lead Staff / Commissioner or Entity Responsible
8/9	Parks Commission Regular Business Meeting (Council Chambers) 6:00pm			
	Conversations Cluster Seating Project (Possible Action) (GOAL: Community Building)	x	x	Superintendent Glatt
	Butler Perozzi Plaque Request-Ashland Parks Foundation		x	APF Board President
	Real Estate Deliberations (GOAL: Trail Improvement)		x	Deputy Director Dials
	World Music Festival Partnership Presentation (GOAL: Community Building)	x		Manager Flora/Rogue World Music
9/6	Parks Commission Study Session (Zoom) 6:00pm			
	Oak Knoll Golf Course Operations RFP Outcome - Tentative (GOAL: Oak Knoll)	x		Deputy Director Dials
	Update to Ashland Parks, Trails, and Open Space Plan Adoption (GOAL: Previous BN Goal Completion)	x		Deputy Director Dials
	E. Main Park Update -Planned Documents / Annexation Update (GOAL: E Main Park) (tentative)	x		Deputy Director Dials
	Review of Recreation Programs and Associated Revenue and Expenses (Discussion)	x		Deputy Director Dials
	Gas Powered Small Equipment Inventory/Replacement Schedule (GOAL: Environmental Sustainability)	x		Interim Parks Superintendent Sullivan
	Lookahead Review	x		
9/13	Parks Commission Regular Business Meeting (Council Chambers) 6:00pm			
	Alcohol in Parks Policy & Ordinance Amendment Discussion & Action (GOAL: Community Building)	x	x	Deputy Director Dials
	Lithia Park Master Plan - Tentative Action (GOAL: Previous BN Goal Completion)	x	x	Deputy Director Dials
10/4	Parks Commission Study Session (Zoom) 6:00pm			
	Pool Update - New Liner / Pool Replacement Plans (Goal: Aquatics)	x		Deputy Director Dials
	Lookahead Review	x		Deputy Director Dials
10/11	Parks Commission Regular Business Meeting (Council Chambers) 6:00pm			
	Q1 FY24 Budget Report		x	Analyst Kiewel
	Lithia Park Master Plan - Tentative Discussion (GOAL: Previous BN Goal Completion)	x	x	Commissioner Landt
11/1	Parks Commission Study Session (Zoom) 6:00pm			
	Lookahead Review	x		Deputy Director Dials
11/8	Parks Commission Regular Business Meeting (Council Chambers) 6:00pm			
	Ashland Parks Foundation Annual Report	x		APF Board President
12/6	Parks Commission Regular Business Meeting (Council Chambers) 6:00pm			
	Standard Memorial Report		x	Interim Parks Superintendent Sullivan
	APRC Subcommittees			
	Ashland Senior Advisory Committee - September 11 (Ashland Senior Center 3:30pm)			Superintendent Glatt
	Ashland Japanese Garden Advisory Subcommittee - July 25 (Lithia Cabin 2:00pm)			Deputy Director Dials
	Bee City USA Subcommittee - TBD			Nature Center Manager VanWyhe
	Current Parks, Conservation, and Maintenance Subcommittee - TBD			Deputy Director Dials
	Golf Course Subcommittee - TBD			Deputy Director Dials
	Long Range Planning Subcommittee - TBD			Deputy Director Dials
	Recreation Division Advisory Committee - Aug. 17 (Lithia Cabin 4:00pm)			Deputy Director Dials
	Trails Master Plan Review Subcommittee - TBD (Lithia Cabin TBD)			Deputy Director Dials
	AD HOC Parks & Open Space Map Update Subcommittee - TBD (Lithia Cabin TBD)			Deputy Director Dials
	Council Business / Budget Meetings			
8/15/2023	Real Estate Acquisition			
	Parking Lot Topics			
	Lithia Hillside/Glenview Trail Proposal Public Input			Deputy Director Dials
	Mission, Vision and Values Report (GOAL: Master Plan)			Manager Flora
	Butler Perozzi Fountain Fundraising Update			Deputy Director Dials
	Long Term Maintenance Reduction Policy (GOAL: Previous BN Goal Completion)			Deputy Director Dials
	Wildfire Mitigation Policy (GOAL: Previous BN Goal Completion)			Deputy Director Dials
	Pickleball Rules Discussion			Deputy Director Dials
	Potential Process for Commissioner Appointment to Position #1 if Vacated			Deputy Director Dials
	Annual Reports			
	Ashland Parks Foundation Annual Report (November)			APF President
	Standard Memorial Report (December)			Director Black
	Volunteers in Parks Report (January/December)			Coordinator Shelton